

Product Name:

PAETEC's Event Conferencing

Availability:

PAETEC's Event Conferencing is available to all markets.

Ideal Customer Profile

Companies that host frequent investor calls, press releases, international meetings, large corporate events, etc., will benefit from PAETEC's reservation-based, high-end conferencing service.

CPE Requirements:

There is no additional CPE required.

Event Conferencing | In Brief

Product Description

PAETEC's Event Conferencing is a reservation-based conferencing service. Typically used for large, formal conferences, it can accommodate over 3,000 participants and is provisioned with a live operator for mediation and conference management. Participants are given an 800 or Direct Inward Dialing (DID) number, unique to that scheduled conference, in order to access the call. Additional security codes can be assigned if the call chairperson decides it is necessary.

Product Capabilities

Operator management – a dedicated operator is available to assist several functions within a conference call. Operators can greet and introduce participants, manage Q&A sessions with the call chairperson, and mute lines if necessary.

International conferencing

Recording / playback – participants who join a conference call after its start can utilize the Post View Playback feature, listening to the call at a later time

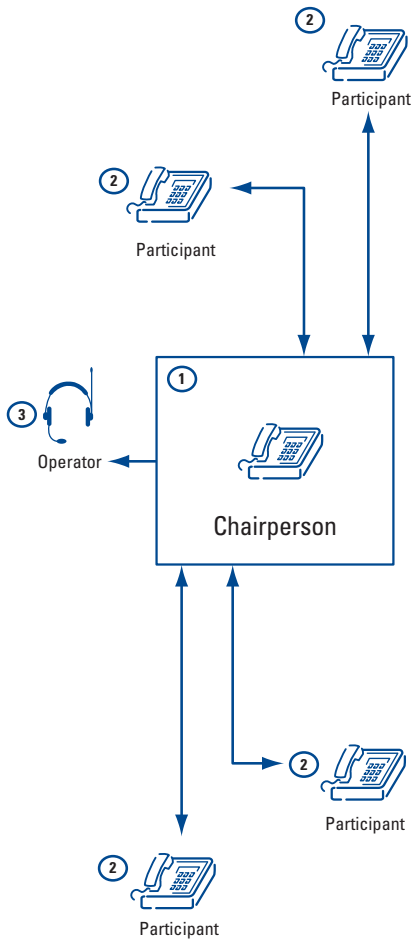

Application One:

Ike's International Corporation (IIC), which employs over 2,600 employees worldwide, hosts monthly press conferences for its foreign investors from the headquarters in Chicago, Illinois. Because unwarranted individuals were previously participating in sensitive conference calls, IIC invested in PAETEC's high-end Event Conferencing, which facilitates secure, managed conference calls. IIC reserves a date and time for their conference call, ensuring a live, dedicated operator is available to manage admittance and roll call, formally greet each participant, and manage the Q&A session. IIC is now confident that their international communications between headquarters and foreign investors is secure, reliable, and efficient.

Application Two:

Meredith's Marketing Firm, headquartered in Hartford, Connecticut, conducts frequent investor meetings with international partners. In order to offer a more comprehensive conferencing session, Meredith's Marketing Firm utilizes PAETEC's Event Conferencing. By recording the meeting, call participants who are unavailable to participate in the call can use the Post View Playback feature that allows them to dial in and listen to the call at a later time. PAETEC facilitates reservation-based calls for investor meetings and allows Meredith's Marketing Firm to manage the recording and playback of their conference calls. In addition, a dedicated operator assists in managing roll call, allowing the call chairperson from Meredith's Marketing Firm to concentrate on the investor presentation.